



## Energy Environment Solutions for Sustainable Growth

# Float Trap Module



## STEAM ENGINEERING

### GENERAL

The main function of steam trap is to permit steam condensate to flow out while retaining steam within the system.

Steam trap is usually provided with inlet, outlet and bypass valves. Strainer and Non-return valve (Disc check valve, DCV) is also included. Installation of all these components in a well-designed sequence is time consuming and difficult, when done at site.

Thermax offers VARIO Float Trap Module is a ready to install pre-fabricated assembly comprising of float trap with inbuilt sight glass, valves, strainers, disc check valves, pipes and fittings.

### TECHNICAL SPECIFICATIONS

Description	MOC
Inlet Gate Valve	ASTM A105 Gr. B
Y-Strainer	SS Body with SS Internals
Float trap with Thermostatic Air Vent	GGG 10.3 with SS internals
Test Valve	ASTM A105 Gr.B
Disc Check Valve	SS Body with SS internals
Outlet Gate Valve	ASTM A105 Gr. B
Bypass Globe Valve	ASTM A105 Gr. B
Inter Connecting Piping	ASTM A 106 Gr. B
End Connection Flanged	ASA #150/300 ANSI 16.5

# MODELS & TRAP SIZES

	FTMOD 15NB	FTMOD 20NB	FTMOD 25NB	FTMOD 40NB	FTMOD 50NB
A	985	1070	1165	1465	1570
B	1185	1270	1365	1715	1820
W	200	200	220	300	350

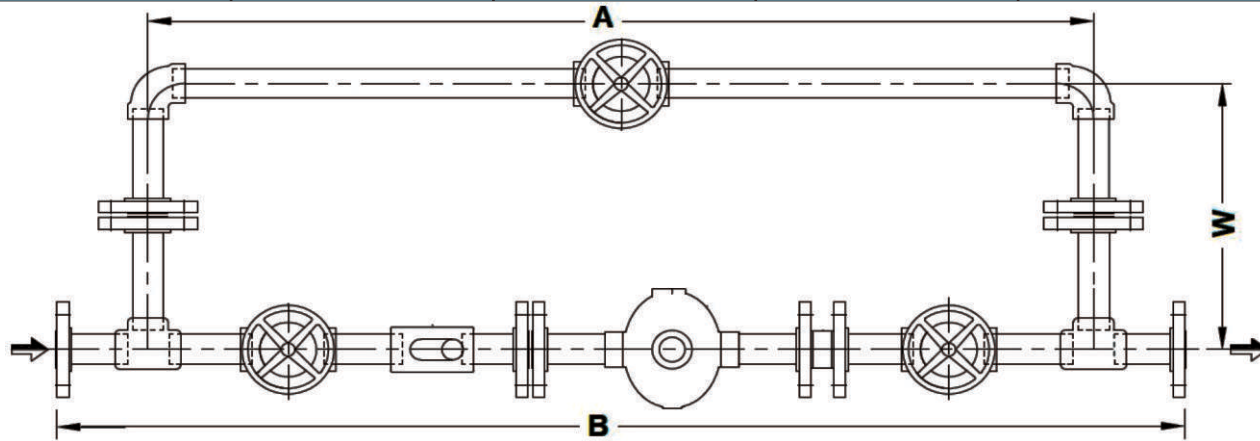

## INSTALLATION REQUIREMENTS

- Entire FT module should be properly supported.
- By pass valve preferably should be in vertical plane
- Test Valve provided after the Float trap, should preferably drain downwards.
- The entire FT module should be given a slight downward gradient so that condensate drains out by gravity at shut down
- Ensure free movement of condensate from equipment to trap module preferably by gravity.
- Ensure trap module is located close to the equipment.

## TECHNICAL SPECIFICATIONS

Connections	Flanged to ASME B16.5, Class 150#
Options	End connection as per ASME B16.5 class 150# With standard ball valve With bellow seal globe valve

## HOW TO ORDER?

- Please provide following details -
- Steam Consuming Equipment :
  - Process temperature required °C :
  - Average Condensate Load (kg/hr) :
  - Steam Inlet Pressure (kg/cm<sup>2</sup>) :
  - Back Pressure (kg/cm<sup>2</sup>) :

Product of RIFOX GmbH - A THERMAX group company



[www.thermaxglobal.com](http://www.thermaxglobal.com)

Publication No. :

Ver. 0 - APR 2019

### Registered Office

D-13, MIDC Industrial Area,  
R D Aga Road, Chinchwad,  
Pune 411019, India

[enquiry@thermaxglobal.com](mailto:enquiry@thermaxglobal.com)

Customer Care: 1800-209-0115



[www.linkedin.com/company/thermax](http://www.linkedin.com/company/thermax)

### Thermax Business Portfolio

- Heating
- Cooling
- Steam Engineering
- Air Pollution Control
- Chemicals
- Water and Wastewater Solutions
- Solar
- Power